

FOLDABLE RACING WHEEL STAND

- 产品说明书/ User Manual -



EN WARNING

- Please install and use the stand according to instruction.
- Please apply moderate force and avoid strong vibrations when installing and using the product.
- Avoid storing in damp, high-temperature, or oily environments.
- The product features movable cross supports, please be cautious to avoid pinching your hands during use.
- The product contains easily detachable parts, children should use the product under the supervision of an adult.

DE WARNUNG

- Bitte installieren und verwenden Sie den Ständer gemäß der Anleitung.
- Bitte wenden Sie bei der Installation und Verwendung des Produkts nur mäßige Kraft an und vermeiden Sie starke Vibrationen.
- Vermeiden Sie die Lagerung in feuchten, heißen oder öligen Umgebungen.
- Das Produkt verfügt über bewegliche Querstreben. Achten Sie bitte darauf, sich bei der Verwendung nicht die Hände einzuklemmen.
- Das Produkt enthält leicht abnehmbare Teile. Kinder sollten das Produkt nur unter Aufsicht von Erwachsenen verwenden.

FR AVERTISSEMENT

- Veuillez installer et utiliser le support conformément aux instructions.
- Veuillez appliquer une force modérée et éviter les vibrations fortes lors de l'installation et de l'utilisation du produit.
- Éviter de stocker dans des environnements humides, à haute température ou huileux.
- Le produit comporte des supports croisés mobiles ; veuillez faire attention à éviter de vous pincer les mains pendant l'utilisation.
- Le produit contient des pièces facilement amovibles ; les enfants doivent utiliser le produit sous la surveillance d'un adulte.

IT AVVERTENZA

- Si prega di installare e utilizzare il supporto secondo le istruzioni.
- Applicare una forza moderata ed evitare vibrazioni intense durante l'installazione e l'uso del prodotto.
- Evitare di riporre il prodotto in ambienti umidi, ad alta temperatura o oleosi.
- Il prodotto presenta supporti incrociati mobili; prestare attenzione per evitare di pizzicare le mani durante l'uso.
- Il prodotto contiene parti facilmente staccabili; i bambini devono utilizzare il prodotto sotto la supervisione di un adulto.

ES ADVERTENCIA

- Debe instalar y utilizar el soporte siguiendo las instrucciones.
- Aplique una fuerza moderada y evite vibraciones fuertes durante la instalación y el uso del producto.
- Evite almacenar el producto en entornos húmedos, de alta temperatura o con presencia de aceites.
- El producto cuenta soportes transversales móviles; preste atención para evitar pellizcos en las manos durante su uso.
- El producto contiene partes fácilmente desmontables. Los niños deben utilizarlo bajo la supervisión de un adulto.

RU ПРЕДУПРЕЖДЕНИЕ

- Установите и используйте подставку в соответствии с инструкцией.
- При установке и использовании изделия прилагайте умеренные усилия и избегайте сильных вибраций.
- Не храните изделие во влажной, высокотемпературной или маслянистой среде.
- Изделие оснащено подвижными крестообразными опорами. Будьте осторожны, чтобы не защемить руки во время использования.
- Изделие содержит легко снимаемые детали. Дети должны использовать изделие под присмотром взрослых.

NL WAARSCHUWING

- Installeer en gebruik de standaard volgens de instructies.
- Oefen matige kracht uit en vermijd sterke trillingen bij het installeren en gebruiken van het product.
- Bewaar het product niet in vochtige, warme of olieachtige omgevingen.
- Het product is voorzien van beweegbare dwarsbalken. Wees voorzichtig om beknelling van uw handen tijdens het gebruik te voorkomen.
- Het product bevat gemakkelijk te verwijderen onderdelen. Kinderen dienen het product onder toezicht van een volwassene te gebruiken.

PT OSTRZEŻENIA

- Instale e utilize o suporte de acordo com as instruções.
- Aplique força moderada e evite vibrações fortes durante a instalação e uso do produto.
- Evite armazenar em ambientes úmidos, de alta temperatura ou com presença de óleo.
- O produto possui suportes cruzados móveis; tenha cuidado para não prender as mãos durante o uso.
- O produto contém partes facilmente destacáveis; crianças devem utilizá-lo sob supervisão de um adulto.

PL OSTRZEŻENIE

- Proszę zainstalować i używać stojaka zgodnie z instrukcją.
- Podczas instalacji i użytkowania produktu należy stosować umiarkowaną siłę i unikać silnych wibracji.
- Unikać przechowywania w wilgotnym, gorącym lub zaolejonym środowisku.
- Produkt posiada ruchome wsporniki poprzeczne, należy zachować ostrożność, aby uniknąć przytraśnięcia dłoni podczas użytkowania.
- Produkt zawiera łatwo odłączalne części, dlatego dzieci powinny korzystać z produktu pod nadzorem osoby dorosłej.

日本語 警告

- 必ず取扱説明書に従ってスタンドを設置・使用してください。
- 設置および使用時は適度な力を加え、強い振動を避けてください。
- 湿気・高温・油分の多い環境での保管は避けてください。
- 本製品には可動式のクロスサポートがあります。使用中に手を挟まないよう十分ご注意ください。
- 本製品には容易に取り外せる部品が含まれています。お様が使用する際は必ず大人の監督のもとでご使用ください。

繁體 警告

- 請按照說明書所示安裝和使用本產品。
- 安裝使用時注意力度適中，避免強烈振動。
- 避免存放於潮濕、高溫、油煙等場所。
- 產品結構為可活動交叉支撐，使用本產品時請小心夾手。
- 產品含有易拆卸零配件，兒童請在成年人的監護下使用本產品。

简体中文 警告

- 请按照说明书所示安装和使用本产品。
- 安装使用时注意力度适中，避免强烈振动。
- 避免存放于潮湿、高温、油烟等场所。
- 产品结构为可活动交叉支撑，使用本产品时请小心夹手。
- 产品含有易拆卸零配件，儿童请在成年人的监护下使用本产品。

深圳市莱仕达电子科技有限公司

型号: A11 产品名称: 直驱赛车模拟器 客服热线: 400 600 3586 客服邮箱: lsd@e-pxn.com
客服QQ: 4006003586 官网: www.e-pxn.com.cn 地址: 深圳市宝安区西乡中熙ECO国际大厦1701-1706

Brand: PXN Model: A11 Product Name: Gaming Racing Wheel Foldable Stand
Manufacturer: Shenzhen PXN Electronics Technology Co., Ltd Country of Origin: China
Web: www.e-pxn.com Support email: support@e-pxn.com
Manufacturer address: 1701-1706(01), Building 8, Zhongxi Xiangbinshan Garden, Fenghuanggang Community, Xixiang Street, Baoan District, Shenzhen, China



EUREP GmbH
Unterlettenweg 1a
85051 Ingolstadt Germany
+49 841 8869 7744
eurep@eurep-gmbh.com







UK001732867424878mGim

We simply act as UK representative for cross-border sellers, and are not manufacturers/importers/distributors for the product, nor involved in the manufacture/import/sale of the product. Therefore, we are not responsible for any after-sales services related to the product. In case of any product quality or infringement issues, the manufacturer/importer/seller shall be solely held responsible.

EVATOST CONSULTING LTD
Office 101 32 Threadneedle Street,
London, United Kingdom, EC2R 8AY
contact@evatost.com

"PXN" is a registered trademark of ShenZhen PXN Electronics Technology Co., Ltd

   : PXNgame
 YouTube : PXN Official
 Discord : PXN



MADE IN CHINA

FCC Compliance Statement:

This device complies with Part 15 of the FCC Rules. Operation is subject to the following two conditions:

1. This device may not cause harmful interference, and
2. This device must accept any interference received, including interference that may cause undesired operation.

Note: This equipment has been tested and found to comply with the limits for a Class B digital device, pursuant to Part 15 of the FCC Rules. These limits are designed to provide reasonable protection against harmful interference in a residential installation. This equipment generates, uses and can radiate radio frequency energy and, if not installed and used in accordance with the instructions, may cause harmful interference to radio communications.

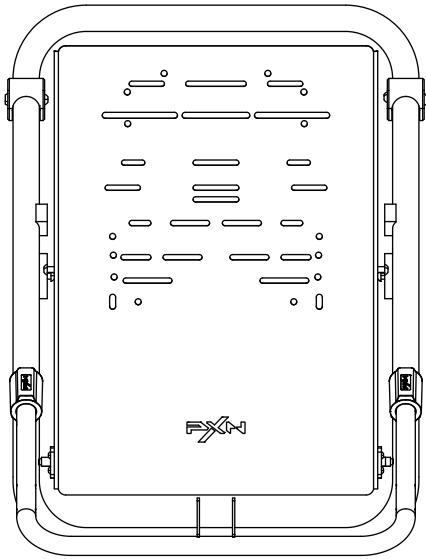

x1

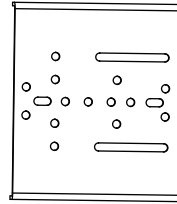

x1

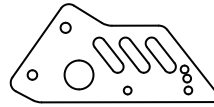

x1

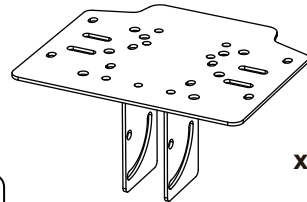

x1

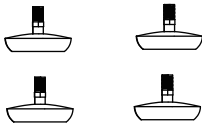

x4

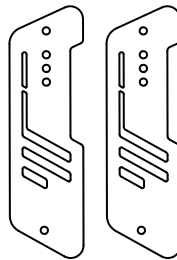

x2

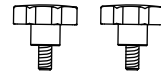

x2

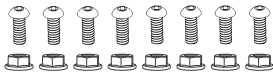

TM6*20mm x8

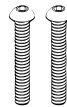

TM6*45mm x2



KM8*20mm x6



TM8*20mm x2



TM6*12mm x2

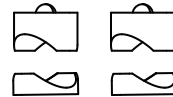

x4

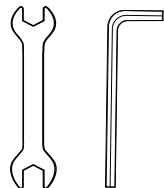

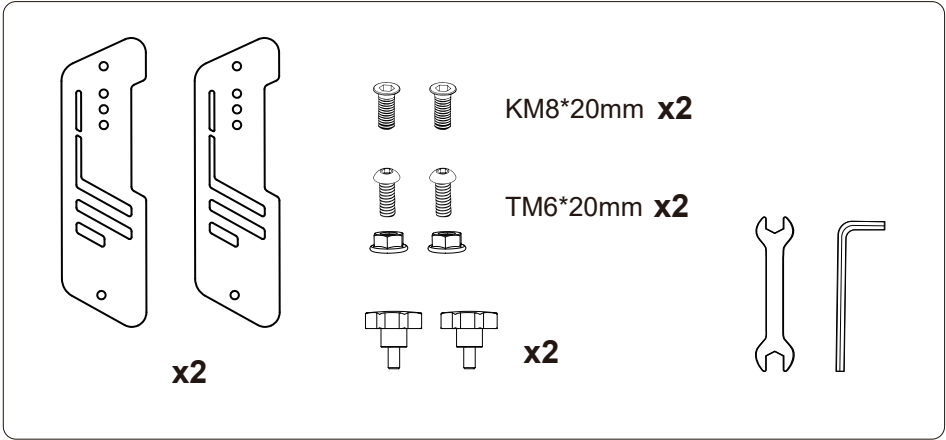

1.

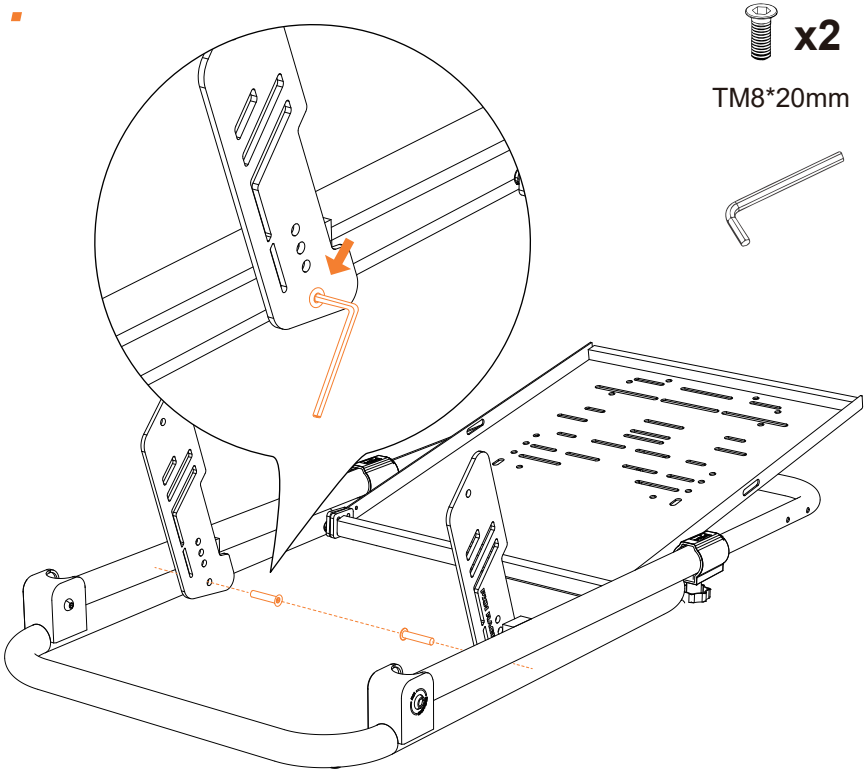

2.

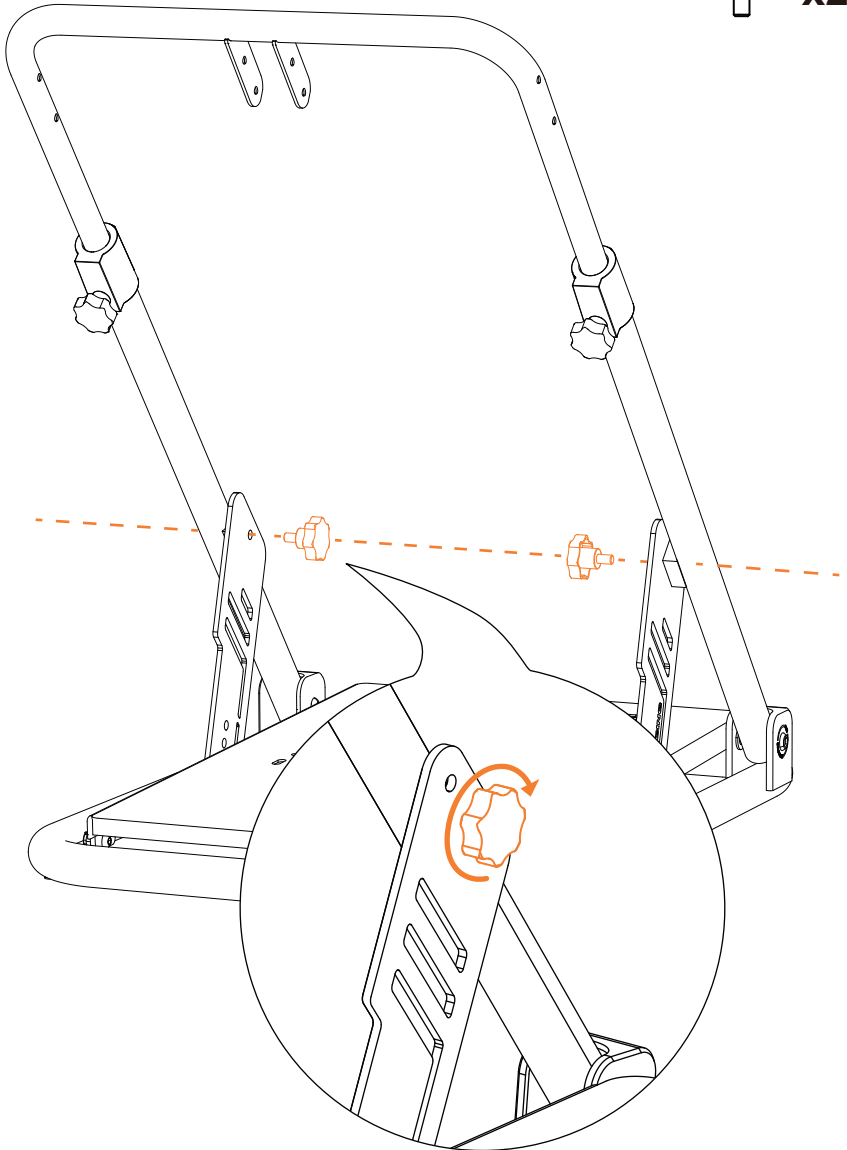

3.

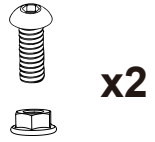

x2

TM6*20mm

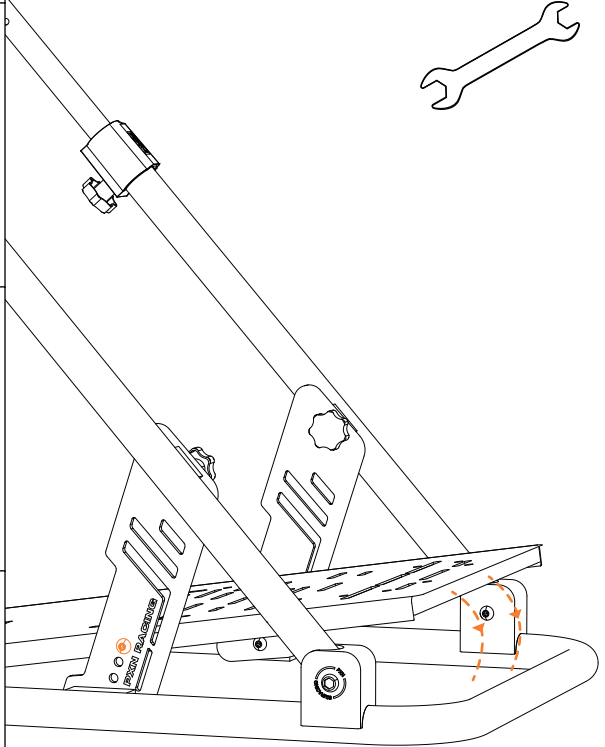
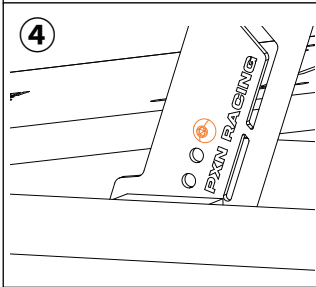
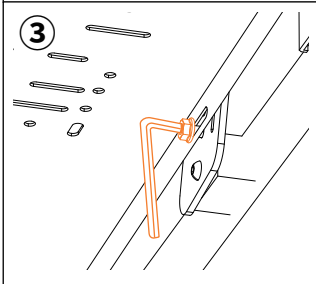
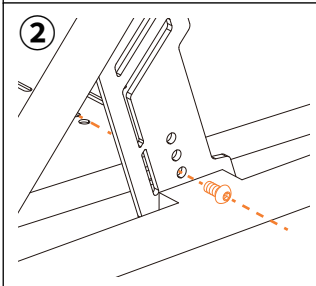
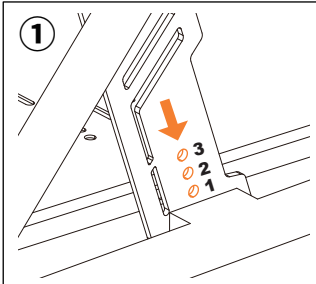
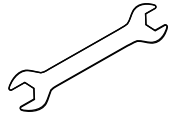
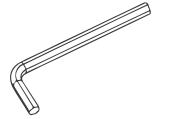

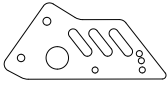

x1



TM6*45mm **x2**

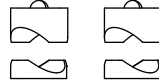

x4



x1

4.

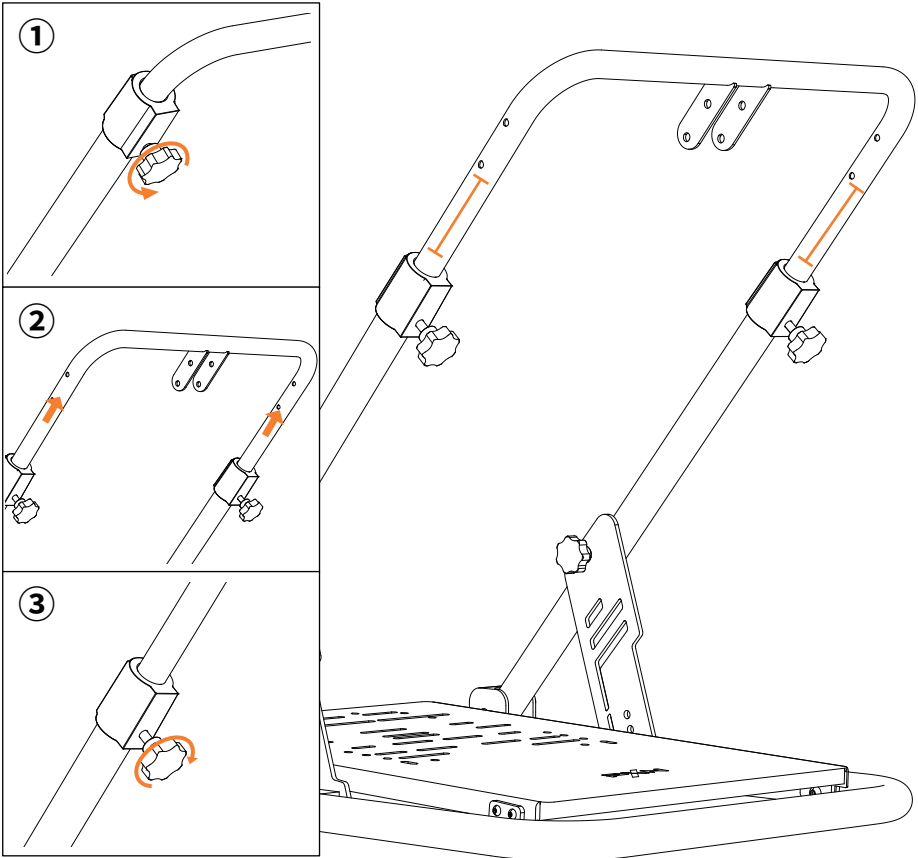

5.

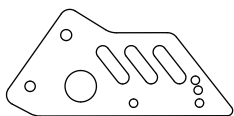

x1



x2

TM6*45mm

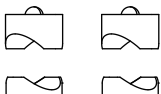

x4

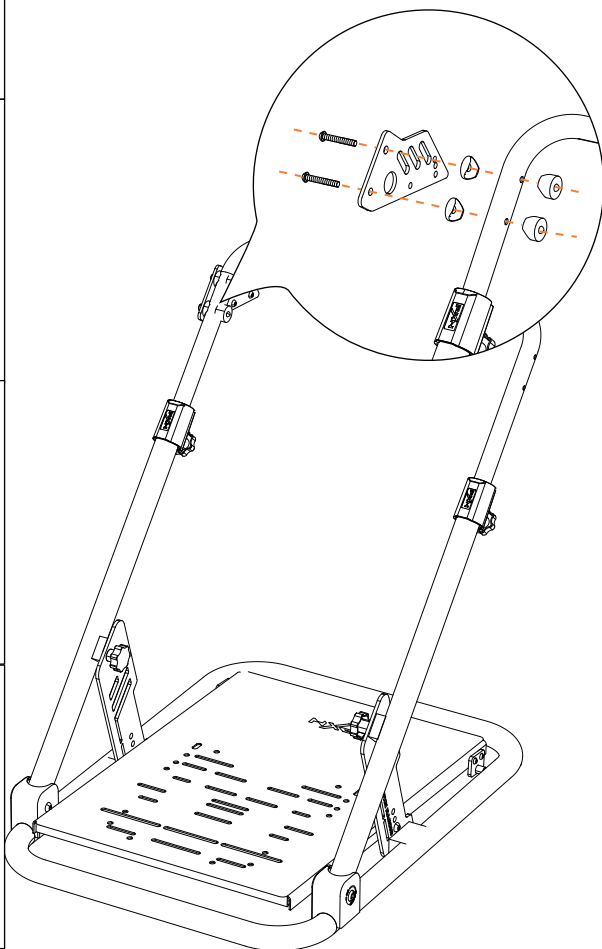
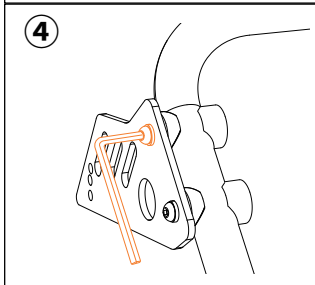
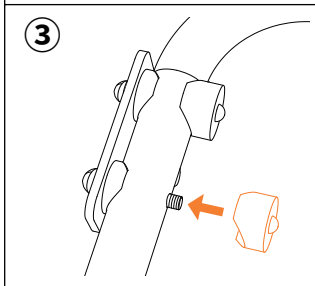
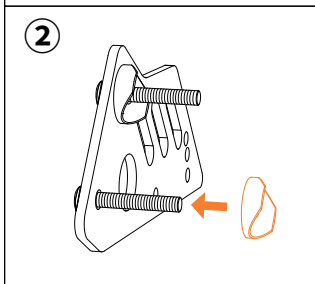
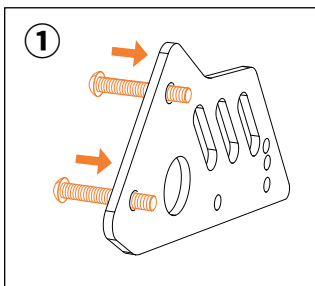
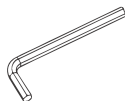

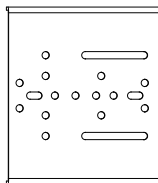

x1



TM6*12mm x2



x1

6.

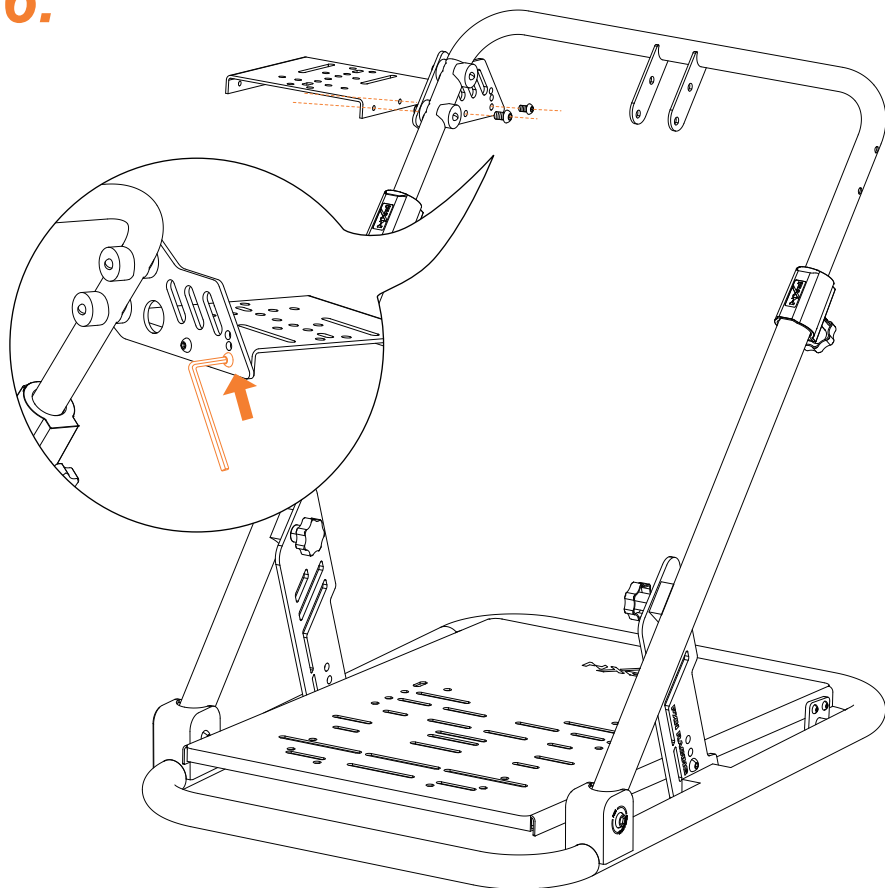

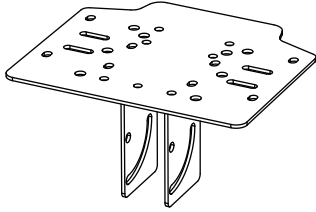

x1

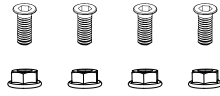

KM8*20mm x4

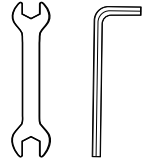

x1 x1

7.

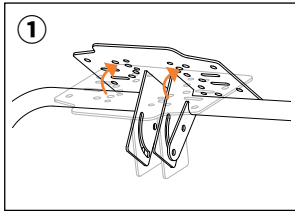

1

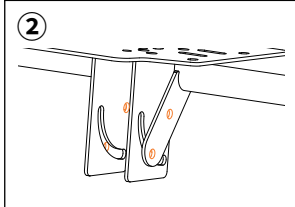

2

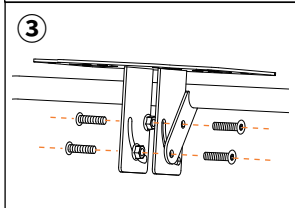

3

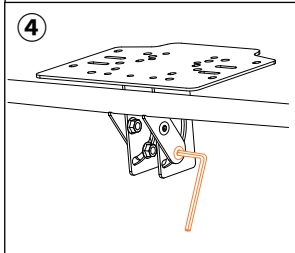

4

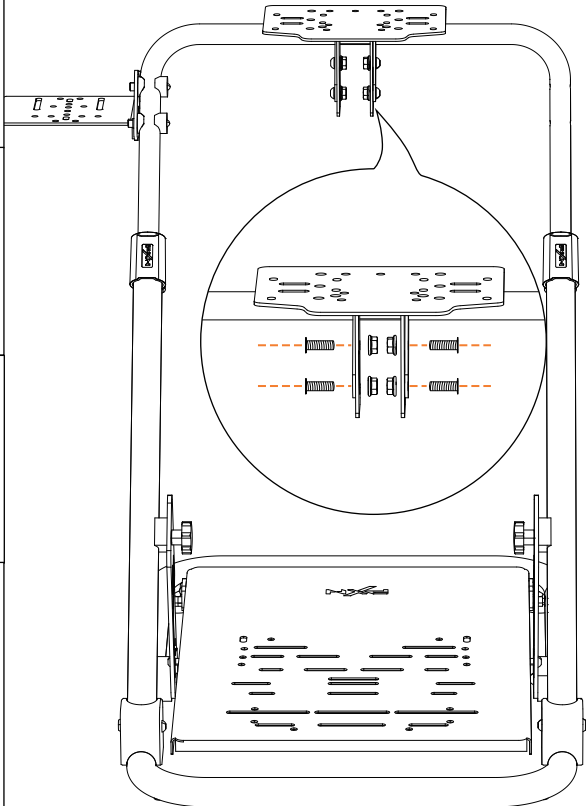

8.

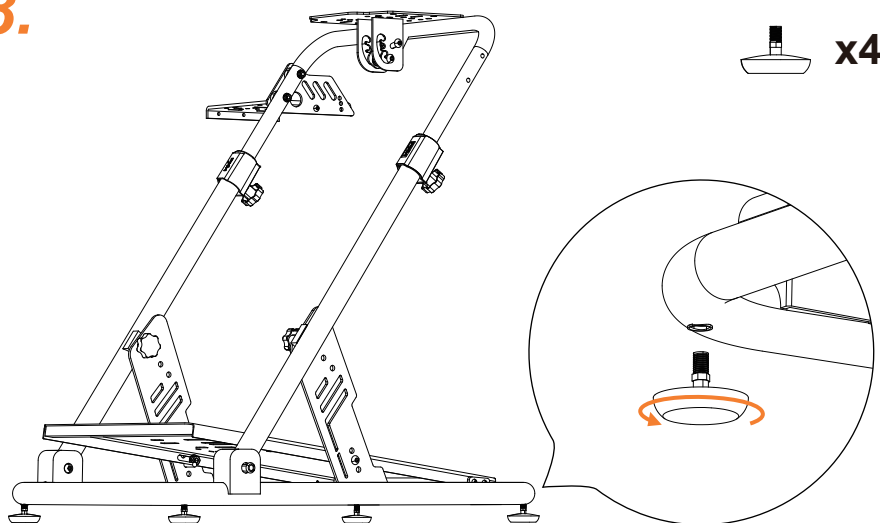

EN Product Specifications

Model: A11	
Product Dimensions: About 56 * 82.5 * 13 cm (Folded) / 72 * 79 * 80 cm (Unfolded)	
Package Dimensions: About 58 * 12 * 91 cm	Operating Temperature: 10-40°C
Product Weight: About 14.2 kg	Operating Humidity: 20~80%

DE Produktspezifikationen

Modell: A11	
Produktmaße: Ca. 56 * 82.5 * 13 cm (zusammengeklappt) / 72 * 79 * 80 cm (aufgeklappt)	
Verpackungsmaße: Ca. 58 * 12 * 91 cm	Betriebstemperatur: 10-40°C
Produktgewicht: Ca. 14.2 kg	Betriebsfeuchtigkeit: 20~80%

FR Spécifications techniques

Modèle: A11	
Dimensions du produit: Environ 56 * 82.5 * 13 cm (Plié) / 72 * 79 * 80 cm (Déplié)	
Dimensions du colis: Environ 58 * 12 * 91 cm	Température d'utilisation: 10°C à 40°C
Poids du produit: Environ 14.2 kg	Humidité d'utilisation: 20% à 80%

IT Specifiche Tecniche

Modello: A11	
Dimensioni della prodotto: Circa 56 * 82.5 * 13 cm (Ripiegato) / 72 * 79 * 80 cm (Completamente esteso)	
Dimensioni della confezione: Circa 58 * 12 * 91 cm	Temperatura operativa: 10-40°C
Peso del prodotto: Circa 14.2 kg	Umidità operativa: 20~80%

ES Especificaciones

Modelo: A11	
Dimensiones del producto: Aprox. 56 * 82.5 * 13 cm (Plegado) / 72 * 79 * 80 cm (Desplegado)	
Dimensiones del paquete: Aprox. 58 * 12 * 91 cm	Temperatura operativa: 10-40°C
Peso del Producto: Aprox. 14.2 kg	Humedad operativa: 20~80%

RU Технические характеристики продукта

Модель: A11	
Размеры продукта: Около 56 * 82.5 * 13 см (В сложенном виде) / 72 * 79 * 80 см (В разложенном виде)	
Размеры упаковки: Около 58 * 12 * 91 см	Température d'utilisation: 10-40°C
Вес продукта: Около 14.2 кг	Humidité d'utilisation: 20%~80%

NL Productspecificaties

Model: A11	
Productafmetingen: Ongeveer 56 * 82.5 * 13 cm (Opgevouwen) / 72 * 79 * 80 cm (Uitgevouwen)	
Verpakkingsafmetingen: Ongeveer 58 * 12 * 91 cm	Werktemperatuur: 10-40°C
Productgewicht: Ongeveer 14.2 kg	Werkvochtigheid: 20~80%

PT Especificações Técnicas

Modelo: A11	
Dimensões do Produto: Aprox. 56 * 82.5 * 13 cm (Dobrado) / 72 * 79 * 80 cm (Estendido)	
Dimensões da Embalagem: Aprox. 58 * 12 * 91 cm	Temperatura de Operação: 10-40°C
Peso del Producto: Aprox. 14.2 kg	Umidade de Operação: 20~80%

PL Specyfikacje produktu

Model: A11	
Wymiary produktu: Około 56 * 82.5 * 13 cm (Złożony) / 72 * 79 * 80 cm (Rozłożony)	
Wymiary opakowania: Około 58 * 12 * 91 cm	Temperatura pracy: 10-40°C
Waga produktu: Około 14.2 kg	Wilgotność robocza: 20~80%

日本語 製品仕様

モデル: A11	
製品サイズ: 約 56 * 82.5 * 13 cm (折りたたみ時) / 72 * 79 * 80 cm (展開時)	
パッケージサイズ: 約 58 * 12 * 91 cm	動作温度: 10-40°C
製品重量: 約 14.2 kg	動作湿度: 20~80%

繁體中文 產品規格

產品型號: A11	
產品尺寸: 約 56 * 82.5 * 13 cm (收縮時) / 72 * 79 * 80 cm (最大展開時)	
包裝尺寸: 約 58 * 12 * 91 cm	使用溫度: 10-40°C
本體重量: 約 14.2 kg	使用濕度: 20~80%

簡體中文 產品規格

產品型號: A11	
本體尺寸: 約 56 * 82.5 * 13 cm (收縮時) / 72 * 79 * 80 cm (最大展開時)	
包裝尺寸: 約 58 * 12 * 91 cm	使用溫度: 10-40°C
本體重量: 約 14.2 kg	使用濕度: 20~80%